

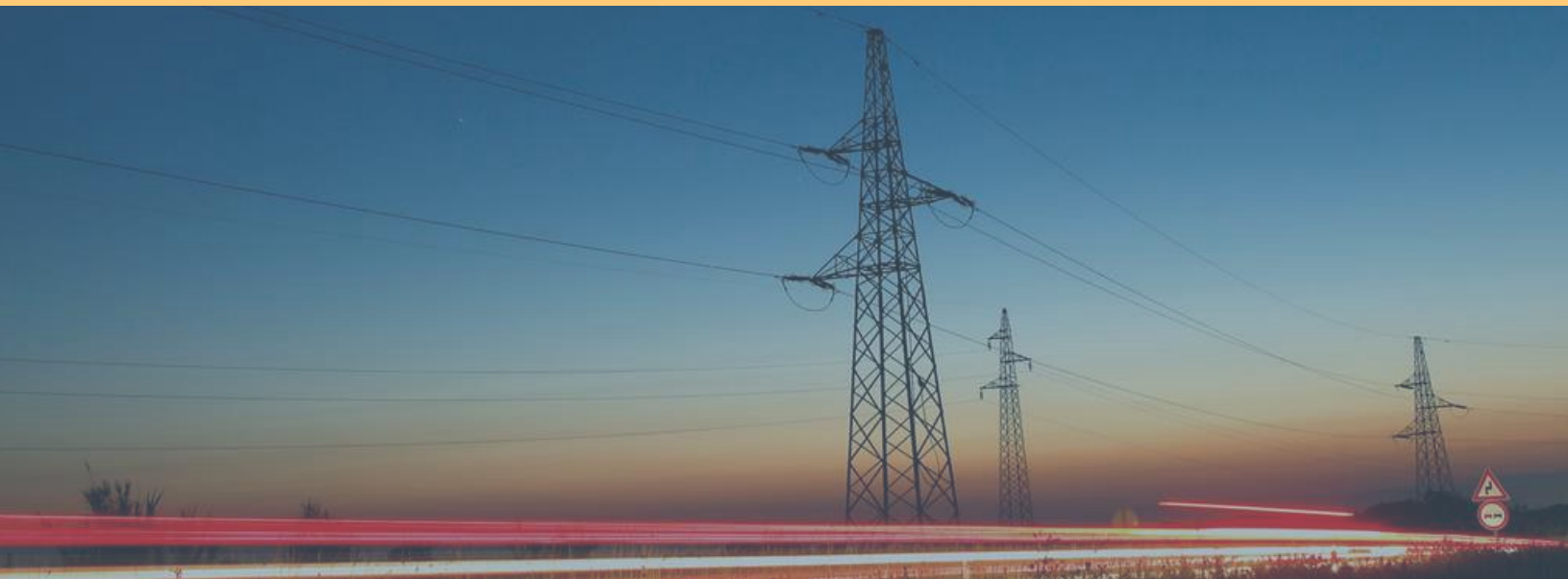

CESER
TECHNICAL ANALYSIS REPORTS

U.S. DEPARTMENT OF
ENERGY | Office of
Cybersecurity, Energy Security,
and Emergency Response

A photograph of high-voltage power lines stretching across a landscape at sunset. The sky is a mix of blue and orange, and the foreground shows a field of tall grass. Light trails from a road are visible at the bottom.

HIGH-ALTITUDE ELECTROMAGNETIC PULSE WAVEFORM APPLICATION GUIDE

July 2023

Table of Contents

Executive Summary	2
E1 and E2 HEMP Vulnerability Assessments	2
E3 HEMP vulnerability Assessments.....	2
Protection of Information	2
Section 1: Introduction	4
High-Altitude Electromagnetic Pulse (HEMP)	4
Potential Impacts of HEMP	5
Need for Vulnerability Assessments	7
Recommended Application of this Guidance Document	7
Report Organization	7
Section 2: E1 HEMP and E2 HEMP Vulnerability Assessments	8
Background	8
Stress	8
Estimating Geographic Coverage of Incident E-Field	8
Determining Localized E-Field	9
Coupling to Devices.....	10
Strength	11
Conducted Threat Testing.....	11
Radiated Threat Testing.....	11
Device Response Modes	12
Determining Susceptibility Levels	13
Assessment (Stress vs. Strength)	13
Performance Requirements	14
Section 3: E3 HEMP Assessments	15
Background	15
Estimating Geographic Coverage of E3 HEMP	15
GIC Calculations	16
Transformer Thermal Analysis	17
Stability Analysis.....	18
Performance Requirements	19
Section 4: Safeguarding Assessments	20
Data Classification	20
Data Storage and Handling.....	20
Sharing Data with U.S. Government Agencies	20
Section 5: References	22

Acknowledgements

Electric Power Research Institute (EPRI), prepared this report for the U.S. Department of Energy under Contract DE-CR0000002.

Executive Summary

The detonation of a nuclear weapon at high altitude or in space can generate an electromagnetic pulse (EMP), referred to as a high-altitude EMP (HEMP), that consists of three components: E1, E2, and E3. Each component is characterized by different spatial and temporal properties. In January 2021, the United States Department of Energy (DOE) released a memorandum detailing recommended E1, E2, E3A and E3B waveforms and electric field (E-field) levels for use in the assessment of electrical systems within critical infrastructure industries (CII). This document, provides high-level technical guidance to CII stakeholders regarding how to conduct HEMP vulnerability assessments, and how to safeguard and share the results with relevant U.S. government agencies.

E1 and E2 HEMP Vulnerability Assessments

E1 and E2 HEMP vulnerability assessments can be performed using a combination of computer modeling and simulation and equipment testing. Modeling of the electrical systems under illumination of HEMP energy, using the DOE provided waveforms and E-field levels, can predict electric stresses to which equipment could be exposed. Due to model complexity, simulations are generally performed over a small geographic area, for example an electric substation. Conducted and radiated testing can be performed to determine the electrical and electromagnetic stresses that a piece of equipment or system is able to withstand without damage or disruption. By comparing the predicted stresses with the measured equipment strength obtained from testing, an estimate of the risk that E1 and E2 HEMP presents to the equipment or system can be determined.

E3 HEMP vulnerability Assessments

E3 HEMP vulnerability assessments involve the modeling of power systems over a large area such as an electrical interconnection. By simulating the coupling to transmission lines by the E3 HEMP energy over a large area, the flow of geomagnetically-induced currents (GIC) in large power transformers can be predicted. Using these predicted GIC, the effects of part-cycle saturation on transformer heating and system stability can be assessed.

Protection of Information

Due to the potentially sensitive nature of HEMP assessment information, measures should be taken to ensure that the information is properly protected. Stakeholders should ensure that information is properly marked and treated as critical energy infrastructure information (CEII) and that NERC critical infrastructure protection (CIP) requirements are followed. When working with a federal agency, CEII is considered controlled unclassified information (CUI) and NIST standard SP-800-171 must be observed.

List of Figures

Figure 1 Comparison of E1, E2 and E3 existing threat fields provided in the DOE memo..... 5

Figure 2 Illustration of the radiated and conducted threat from E1 incident on a substation control building..... 6

Figure 3 E1 vulnerability assessment flowchart 8

Figure 4 Geographic coverage of a notional 1 MT weapon detonated at an altitude of 100s of km 9

Figure 5 Illustration of plane wave coupling into an above ground conductor.....10

Figure 6 Example of a government owned and commercial guided wave test facilities in the United States.....12

Figure 7 Illustration of statistical approach to determine probability of device failure13

Figure 8 Illustration of static spatial E-field generated by E3B HEMP [17]16

Figure 9 Illustration of GIC flow in a simple power systems17

Figure 10 Performance requirements of NERC TPL-007-4.....19

Section 1: Introduction

High-Altitude Electromagnetic Pulse (HEMP)

The detonation of a nuclear weapon at high altitude or in space (~ 30 km or more above the earth's surface) can generate an intense electromagnetic pulse (EMP) referred to as a high-altitude EMP or HEMP. HEMP propagates to the earth and can impact various ground-based technological systems such as the electric power grid. The resulting HEMP, which is generally characterized by three hazard fields, E1, E2 and E3, is a function of the location of the explosion above the earth's surface and weapon yield.

On January 11, 2021, the U.S. Department of Energy (DOE) released a memo [1] which provides recommended parameters for the three HEMP components as summarized below:

- The early time component (E1) is characterized by a double exponential waveform with rise time of 2.5 nanoseconds, pulse width at half maximum of 23 nsec and amplitude of 25 kV/m for existing threats or 50 kV/m for possible future considerations.
- The intermediate time component (E2), which is considered an extension of E1 HEMP, is characterized by a double exponential waveform with pulse width at half maximum of 693 μ sec and amplitude of 50 V/m for existing threats or 100 V/m for possible future considerations.
- The late time component (E3) is comprised of a blast component, E3A, and a heave component, E3B. Parameters for defining these more complicated waveforms are provided in the DOE memo [1]. The peak E3A amplitude is 40 V/km for existing threats or 80 V/km for possible future considerations. Likewise, the peak E3B amplitude is 25 V/km for existing threats and 50 V/km for possible future considerations.
- A graph of the three HEMP components provided in the memo is provided in Figure 1. Note that E1 and E2 are shown on a log-log scale and amplitudes of all four waveforms correspond to possible future threat levels.

A graph of the three HEMP components provided in the memo is provided in Figure 1. Note that E1 and E2 are shown on a log-log scale and amplitudes of all four waveforms correspond to possible future threat levels.

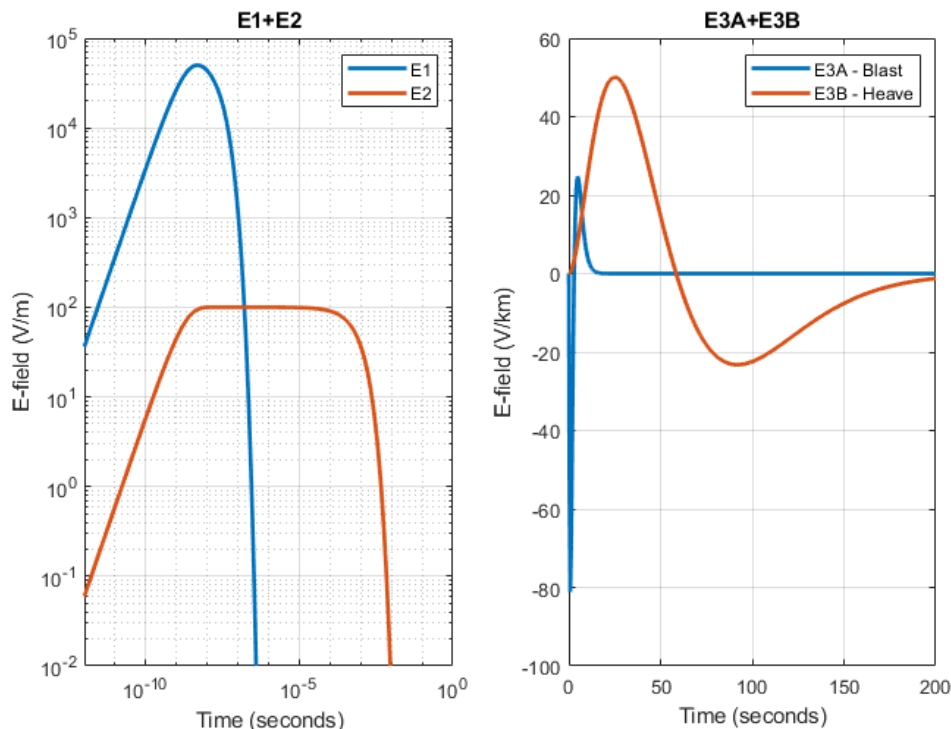

Figure 1

Comparison of E1, E2 and E3 existing threat fields provided in the DOE memo

It is important to note that not all areas included within the impacted area experience the maximum electric field (E-field) levels shown in Figure 1, as these represent worst-cases that might be seen at specific locations on the ground, but not all locations at once. More information on this will be provided in further sections of the report. The interested reader is directed to [2] for a detailed description of the phenomenology of HEMP. Further, it is important to note that these E-field waveforms are estimated threat levels for vulnerability assessments and not prescriptive testing levels or hardening standards.

Potential Impacts of HEMP

E1 is a large amplitude pulse with frequency content in the 100's of MHz; thus, conductive objects like control cables and power lines behave as antennae and absorb the radio frequency (RF) energy of the pulse. In this manner, the incident E1 field couples to overhead lines, control cables and so on and generates conducted voltage and current transients which insult connected equipment. This is referred to as the conducted threat. The incident E1 field can also couple directly to equipment and induce voltages and current transients at the circuit board level which can also lead to device upset or damage. This is referred to as the radiated threat. An illustration of a substation control building with equipment that is subjected to the radiated and conducted threat from E1 is illustrated in Figure 2.

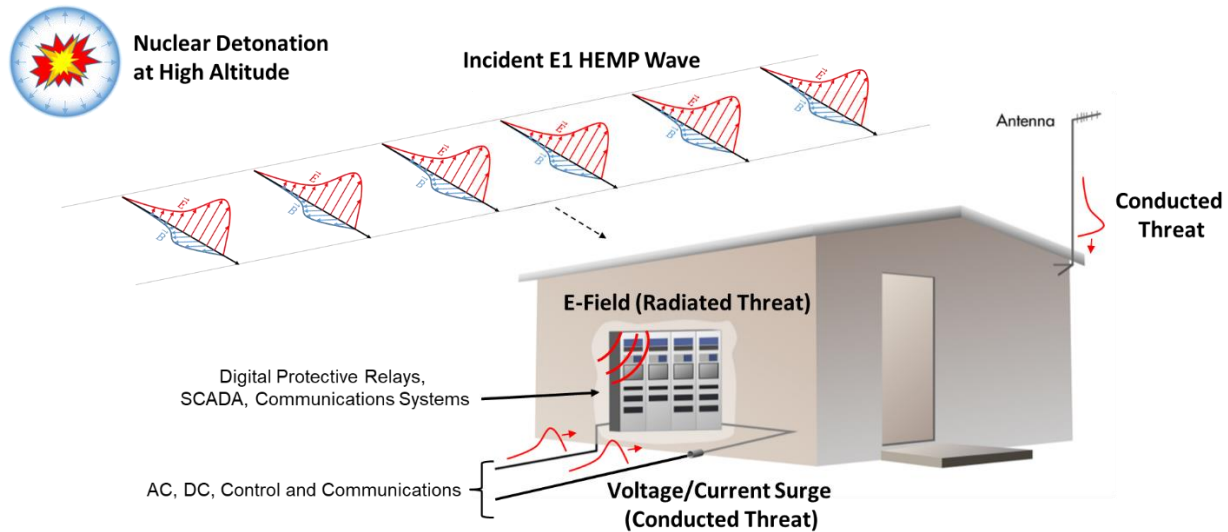

Figure 2

Illustration of the radiated and conducted threat from E1 incident on a substation control building

In an electric power system, E1 can damage or disrupt electronic devices such as digital protective relays (DPRs), communication systems, and supervisory control and data acquisition (SCADA) systems [3]. The resulting voltage surges can also cause insulation flashover of distribution-class insulators and transformers.

The characteristics of E2 are similar to the electromagnetic (EM) fields generated by nearby lightning strikes where the EM fields couple through the air to overhead lines and cables. E2 can also pose a threat from both a radiated and conducted perspective. Because of the low amplitude of the E2 E-field, the radiated threat is generally insignificant, and the coupled conducted threat is lower than the threat posed by lightning. Thus, E2 is generally not considered an issue for transmission voltage levels or distribution systems that have adequate lightning protection [3],[4]. However, it bears mentioning that not all areas of the United States experience frequent lightning, and some utilities are less protected than others against this threat.

E3 induces low-frequency (quasi-dc) currents in transmission lines and bulk power system transformers that have grounded wye windings. The flow of these geomagnetically induced currents (GIC) in transformer windings can cause magnetic saturation of transformer cores, which causes the transformers to generate harmonic currents, absorb significant quantities of reactive power, and experience additional hotspot heating in windings and structural parts. Potential impacts of E3 on the electric power grid include voltage collapse (regional blackout), protective equipment misoperation due to harmonics, and transformer damage due to additional hotspot heating [3]. Additionally, certain sensitive power electronics-based loads, for example uninterruptible power supplies, may be prone to disruption or damage due to harmonic voltage distortion that is transferred from the transmission system to medium-voltage and low-voltage systems.

Need for Vulnerability Assessments

Because HEMP is considered a credible threat to the electric power grid and other critical infrastructure sectors, it is important to understand the potential impacts, how the impacts can be mitigated, and the costs associated with mitigating the impacts. The initial step in this process is performing a vulnerability assessment where the performance of the device or system is evaluated against a prescribed threat level such as the ones provided in [1].

Recommended Application of this Guidance Document

This guidance represents the first step in a new conversation between government and industry. It is not expected that industry and regulators will quickly become experts in performing HEMP assessments and implementing HEMP protections. Performing many of these activities is complicated and requires specific expertise and experience that is not commonly found. As such, the technical guidance in this report is not intended to be a detailed step-by-step instruction manual or specification of how to perform these activities, but rather a high-level overview of the information and data that are necessary to perform the assessments.

The DOE recommends that asset owners, operators, and stakeholders focus on simulating, testing, assessing, and protecting the assets and systems in their care, and not on becoming experts in nuclear weapons effects, which requires years to master and data that are not publicly available. The DOE further recommends to entities that want to assess their systems to HEMP vulnerability and consider reducing those risks in a cost-effective way, to reach out to industry experts such as national or commercial laboratories and R&D organizations for assistance.

Report Organization

The remainder of this report is focused on providing the reader with a basic understanding of HEMP vulnerability assessments and how to safeguard the sensitive information and results that come from them. The remainder of the report is organized as follows:

- Section 2 provides an overview of E1 and E2 vulnerability assessments.
- Section 3 provides an overview of E3 vulnerability assessments.
- Section 4 provides an overview of how to safeguard sensitive information and results from HEMP vulnerability assessments.
- Section 5 provides a listing of references used throughout the report

Section 2: E1 HEMP and E2 HEMP Vulnerability Assessments

Background

E1 and E2 can disrupt and/or damage critical electrical components and systems by exposing them to radiated E-fields and conducted voltage and current transients. Thus, HEMP vulnerability assessments must consider both threat scenarios. A flowchart of a process that can be used to perform an E1 vulnerability assessment is illustrated in Figure 3. E2 can be assessed in a similar manner and is not duplicated for brevity.

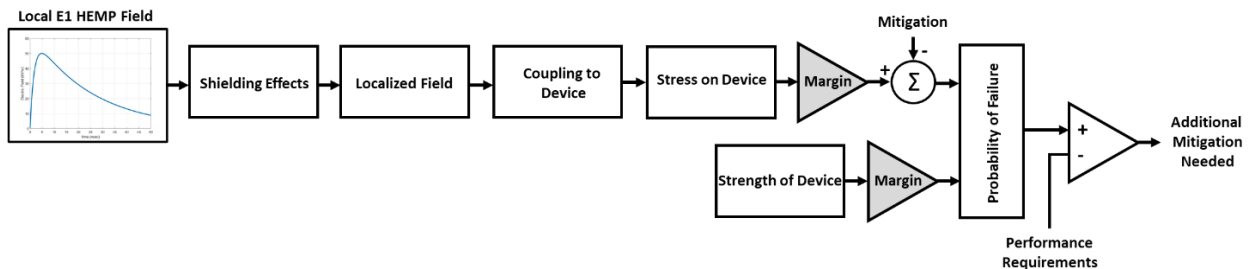

Figure 3
E1 vulnerability assessment flowchart

Using the workflow illustrated in Figure 3 the electrical stress is estimated and compared to the electrical strength of the device. In both cases, design margin is included to account for uncertainties and allow a factor of safety compared to realizable stresses. Mitigation can then be applied to reduce the electrical stress. Lastly, the electrical stress is compared with the electrical strength either statistically or deterministically. When the probability of failure exceeds the specified performance criteria, it is an indication that potential impacts are possible, and mitigation is required to achieve the desired level of performance. The process illustrated in Figure 3 can be performed multiple times until the mitigation design yields a probability of failure that meets or exceeds the performance requirements. The following sections provide additional detail.

Stress

Electrical stress is defined as the E-field level or the level of conducted voltage or current surge that a device may be exposed to during a HEMP attack. Thus, electrical stress is a function of the location of the device or system under consideration (the victim), and the level of shielding and coupling efficiency.

Estimating Geographic Coverage of Incident E-Field

The geographic area exposed to E1 fields can be quite large as the area of illumination is defined by the line of sight from where the weapon is exploded out to the horizon. For example, detonating a weapon at 100's of km above the center of the contiguous United States (CONUS) can expose an area of several million square miles, that can include most of the CONUS and portions of Canada and Mexico, to E1. For illustration purposes, the geographic coverage resulting from a notional 1 MT weapon detonated several 100's of km above CONUS is shown in Figure 4 and illustrates that not all areas are affected the same. Peak electric field amplitudes are shown in per-unit of the maximum E-field level.

Once the geographic coverage is known, the incident E1 field at the location of interest is determined. The local E1 field is a function of the E1 environment that is specified and the location of the victim with respect to the ground zero location. Specific parameters of the local E1 field that are important for assessments include: waveshape, amplitude, polarization, and angle of incidence. The DOE memo provides recommended parameters for the waveshape and amplitude. Polarization and angle of incidence must be assumed for a given scenario.

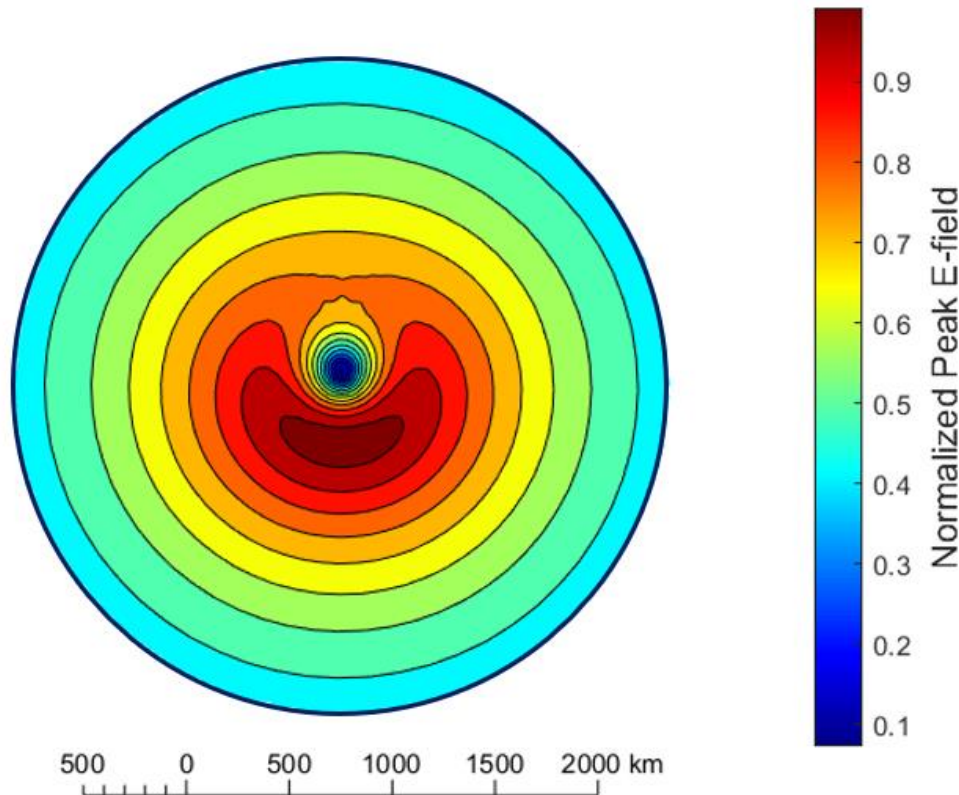

Figure 4
Geographic coverage of a notional 1 MT weapon detonated at an altitude of 100s of km

Determining Localized E-Field

Shielding effects are considered in situations when the victim is located within an enclosure such as a building or buried underground. Shielding is negligible if the victim is located in open air, for example an overhead distribution line or ground level control cable. Shielding effects are typically assessed using 3D modeling software or testing where the shielding effectiveness of the structure is measured, and the corresponding attenuated incident E-field (or localized field shown in Figure 3) is estimated by convolving the incident E-field with a magnitude-only transfer function [5].

Shielding effects can also be estimated if the building construction is known. Six-sided metal buildings can provide a shielding effectiveness on the order of 20-30 dB while concrete and masonry buildings provide less than 10 dB [3]. MIL-STD-188-125-1 compliant enclosures provide 80 dB or more of shielding effectiveness [6].

Once the localized field has been estimated, the electric stress resulting from the conducted and radiated threat can be determined. Users of this guidance are cautioned that not all areas within a given field level will be subject to the same level of damage as devices will be affected by coupling efficiency, shielding, system level effects, and the intrinsic differences in susceptibility levels between devices.

Coupling to Devices

The attenuated incident E-field or the local E-field levels are generally used directly as it is a very complicated process to estimate conducted transients inside of a device. However, it is straightforward to determine the conducted voltage and current transients that the device's terminals could be exposed to.

E1 and E2 can be considered plane waves and plane wave coupling techniques can be used to couple the incident E-field into conductors. Figure 5 illustrates a E1 wave coupling into a straight conductor of length, L , and height, h , above a lossy ground plane. The impedances, Z_1 and Z_2 , represent device or equipment terminations. Voltage and currents are calculated at the end points to determine if the loads may be disrupted or damaged by the coupled energy.

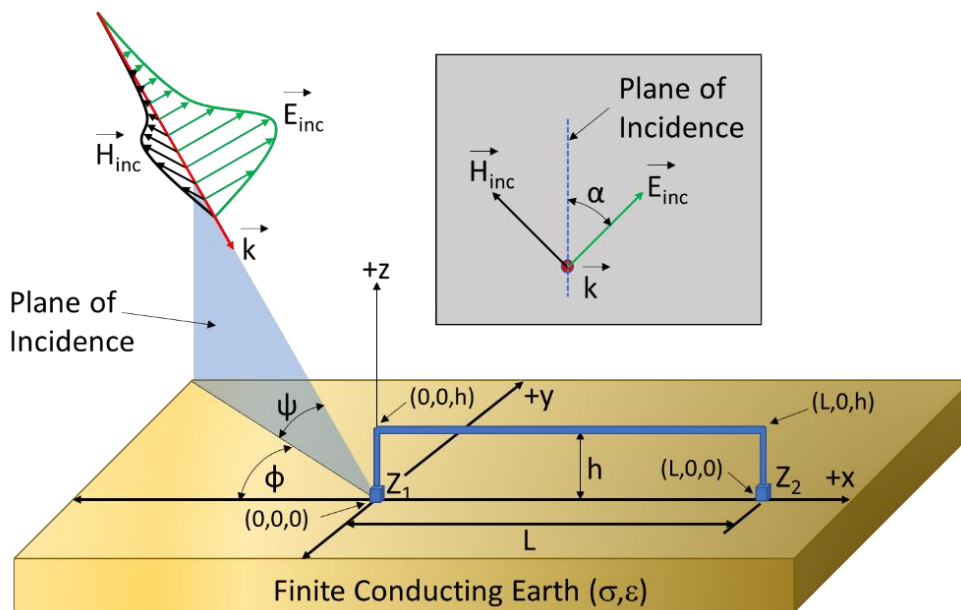

Figure 5
Illustration of plane wave coupling into an above ground conductor

Established plane wave coupling calculation techniques can be used to estimate the conducted voltage and current surges resulting from plane wave coupling to exposed conductors. Modeling methods include the Baum Liu Tesche (BLT) equations [7] using either

Taylor [8] or Agrawal [9] formulations, Olsen's reciprocity [10] approach, or the approach presented in Vance's EMP Handbook [11]. These plane wave coupling calculation methods use transmission line theory to simplify the calculations as complete solutions to electromagnetic coupling problem are quite involved and complicated. While these simplifications can introduce some error [12] they represent methods realizable with modern computing technology that work well to estimate HEMP coupled waveforms.

Important parameters in the determination of coupled voltage and current transients include: incident E-field (amplitude, waveshape, polarization, and angle of incidence), length of the conductor and height above ground, ground conductivity and the termination impedances.

E1 coupled surges tend to reach their peak magnitudes over distances of tens to hundreds of meters [13]. This allows E1 coupling modeling to be performed over relatively small geographic areas.

Strength

Electrical strength is defined as the level of E-field or amplitude and waveshape of the voltage or current surge that a device can withstand without upset or damage. Electrical strength of devices or systems is best determined through laboratory and/or field testing.

Conducted Threat Testing

Pulsed current injection (PCI) or pulsed voltage injection (PVI) testing is performed to determine a device's response to conducted current or voltage transients, respectively. The test uses a high-voltage generator to create a voltage or current impulse that represents an impulse that can be induced into a conductor by E1 or E2. The impulse is typically applied to the conductor directly using a metal oxide varistor (MOV) or coupled using a current transformer (CT). Refer to [3] for an example of PVI testing and [6] for examples of PCI testing.

Radiated Threat Testing

Free field illumination or guided wave testing is performed to determine a device's ability to withstand the effects of an incident electromagnetic plane wave. This type of test is performed using a guided-wave simulator to generate a transient electromagnetic field that is then applied to a device or system. Examples of guided wave test facilities include the U.S. Army's White Sands test facility near Las Cruces, NM and EPRI's test facility in Charlotte, N.C. Photographs of these two test facilities are shown in Figure 6.

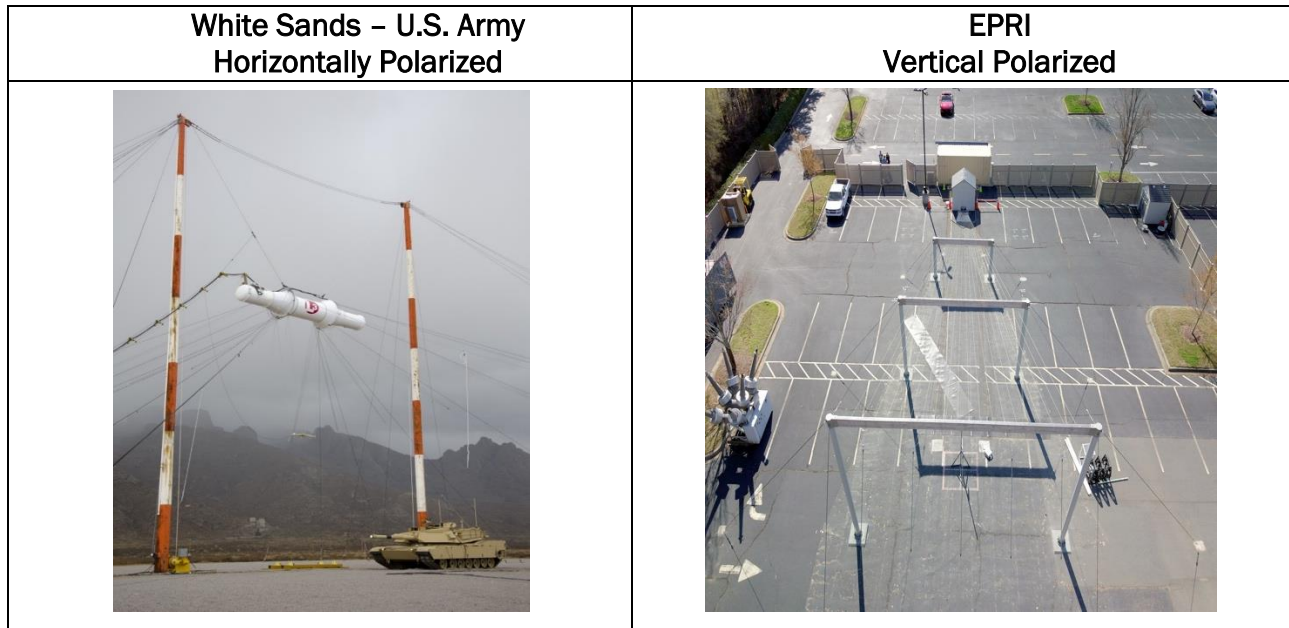

Figure 6

Example of a government owned and commercial guided wave test facilities in the United States

The E-field generated by the White Sands test facility is horizontally polarized whereas the E-field generated by the EPRI facility is vertically polarized. To test against different polarizations, the orientation of the device under test (DUT) is rotated.

Device Response Modes

When performing testing, device or system responses can be classified into four categories: no response, Type 1, Type 2 and Type 3, and are defined in Table 1.

Table 1
Definition of device responses following testing

Device Response	Description	Examples
No Response	No disruption or damage to the device during and after the test	Normal operation observed during and after the test
Type 1	Device disruption; device able to resume normal operation after test without user intervention	Following the test, the device reboots to a stable operating condition without manual intervention
Type 2	Device disruption; manual intervention required to resume normal operation	Following the test, the device becomes disabled, but manually recycling the power returns the device to a normal operating state.
Type 3	Device destruction, repair, and/or replacement of device required	The test causes permanent damage to the device

Determining Susceptibility Levels

Determining device susceptibility levels is an important aspect of evaluating electrical strength of a device. For the radiated threat, the susceptibility level is the E-field level, waveshape and polarization that causes device upset or damage. For conducted threat testing, the susceptibility level is the voltage and/or current surge level and waveshape where device upset or damage is experienced. The levels for a given waveshape are identified by using low levels at the outset of the test and increasing the stress until upset or damage is observed. Determining susceptibility levels through testing is quite different from performing standard compliance testing where the device is tested to a maximum level and a pass/fail grade is given.

Electrical strength data are not always readily available and using similar devices or systems that have been tested to determine the electrical strength of a device or system can be considered. However, caution should always be exercised when doing so as the susceptibility level of devices generally falls within a range and so using limited data can be misleading. Also, the designs of what may appear to be a similar device can be different enough that their response to HEMP threats can be significantly different.

Assessment (Stress vs. Strength)

The final step in the HEMP assessment process is to compare the electrical stress that is predicted through modeling to the electrical strength of the equipment that is determined through testing. Two approaches can be used. A deterministic approach where the worst-case stress is compared with the withstand capability of the device (the level at which no response is observed) is often used due to the lack of statistically significant test data. This approach tends to provide conservative results. When statistically significant test data are available, a statistical approach can be used where a probability distribution function (PDF) is developed for the stress and a cumulative distribution function (CDF) is developed for the strength. An additional PDF is generated by multiplying the stress PDF with the strength CDF. The probability of failure is computed by calculating the area under the 2nd PDF. An example of this approach is illustrated in **Error! Reference source not found.**

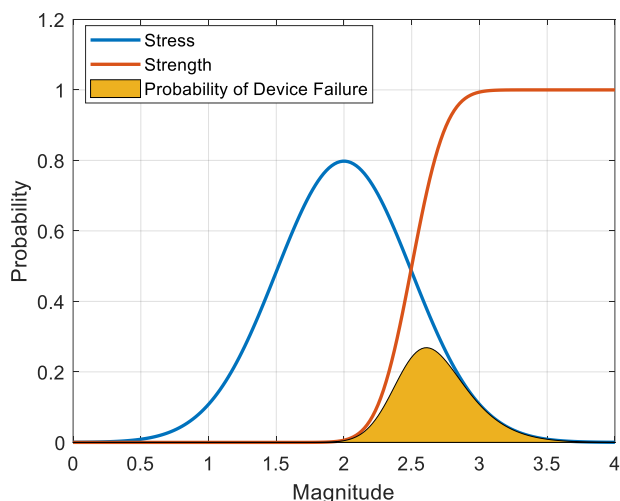

Figure 7

Illustration of statistical approach to determine probability of device failure

The amount of margin that should be included in the assessment process is based on factors such as the criticality of the system and the acceptable amount of downtime. Margin can be used when assessing both radiated and conducted threats, and the amount of margin used may vary between the two.

For radiated threats, margin can be included to account for unknowns in equipment susceptibility levels or building designs. In general, margin associated with radiated threats is included in one of two ways: 1) by reducing the susceptibility level of the component or system or 2) by increasing the required shielding effectiveness level of the building or enclosure that contains the component or system. Reference [14] suggests 20dB as the recommended default margin of error protection; however, for electric utility applications this can be excessive. EPRI recommends using 10dB of design margin for enclosures that contain substation-grade electronics and have moderate levels of shielding, for example six-sided metal substation control buildings [15]. In all applications, additional margin (up to 20 dB total) is recommended when there is considerable uncertainty

Margin for the conducted stress assessment is based on the unknowns associated with performing high frequency transient modeling. Sources of error can originate from the fidelity of the E1 environment, the coupling model and/or the calculations used to perform the simulation. Higher margins should be used when the model is based heavily upon assumptions or has not been sufficiently validated. The use of margin in conducted stress assessments is similar to insulation coordination studies where margins on the order of 2-3 dB have been used by the industry for many years [16]. However, additional margin is recommended when there is considerable uncertainty.

Performance Requirements

Currently, there are no industry established performance requirements for evaluating the impacts of E1 or E2 on the electric grid.

Section 3: E3 HEMP Assessments

Background

Assessing the potential impacts of E3 on the bulk power system is similar to assessing the impacts of geomagnetic disturbance (GMD) events; however, there are some important distinctions. First, the E3 E-fields are much shorter duration than GMD events, generally lasting up to 100's of seconds (refer to Figure 1) as compared with hours or days with a GMD event. Secondly, E3 E-field levels can be an order of magnitude higher than a severe GMD event. Because of these important distinctions, the methods used to assess the potential impacts of E3 can differ from those used to assess severe GMD events. Lastly, the results of E3 assessments should never be used to quantify the effects of a severe GMD event and vice versa, as the two phenomena should always be considered separately.

Estimating Geographic Coverage of E3 HEMP

E3 is comprised of two components, E3A or the blast component and E3B or the heave component. Like the E1 environment, E3 is comprised of temporal and spatial components.

The portion of E3A that is large enough to cause potential disruption of the power grid is generally located thousands of kilometers away from the ground zero location. However, the location of the maximum E3B field is centered around the ground zero location but moves around so that different geographic locations experience varying levels of E-field based on the non-uniformity of the geomagnetic field and local earth conductivity. Generally, the information necessary to properly model the temporal aspects of the spatial component of E3B is not available for the entire United States and so a static footprint such as the one illustrated in Figure 8 is assumed. This can result in over or under estimation of the potential impacts based on the assumptions used. Examples of static laydowns can be found in [4] and [17]. An example of a higher fidelity environment that accounts for the spatial and temporal variance of the E-field can be found in [3].

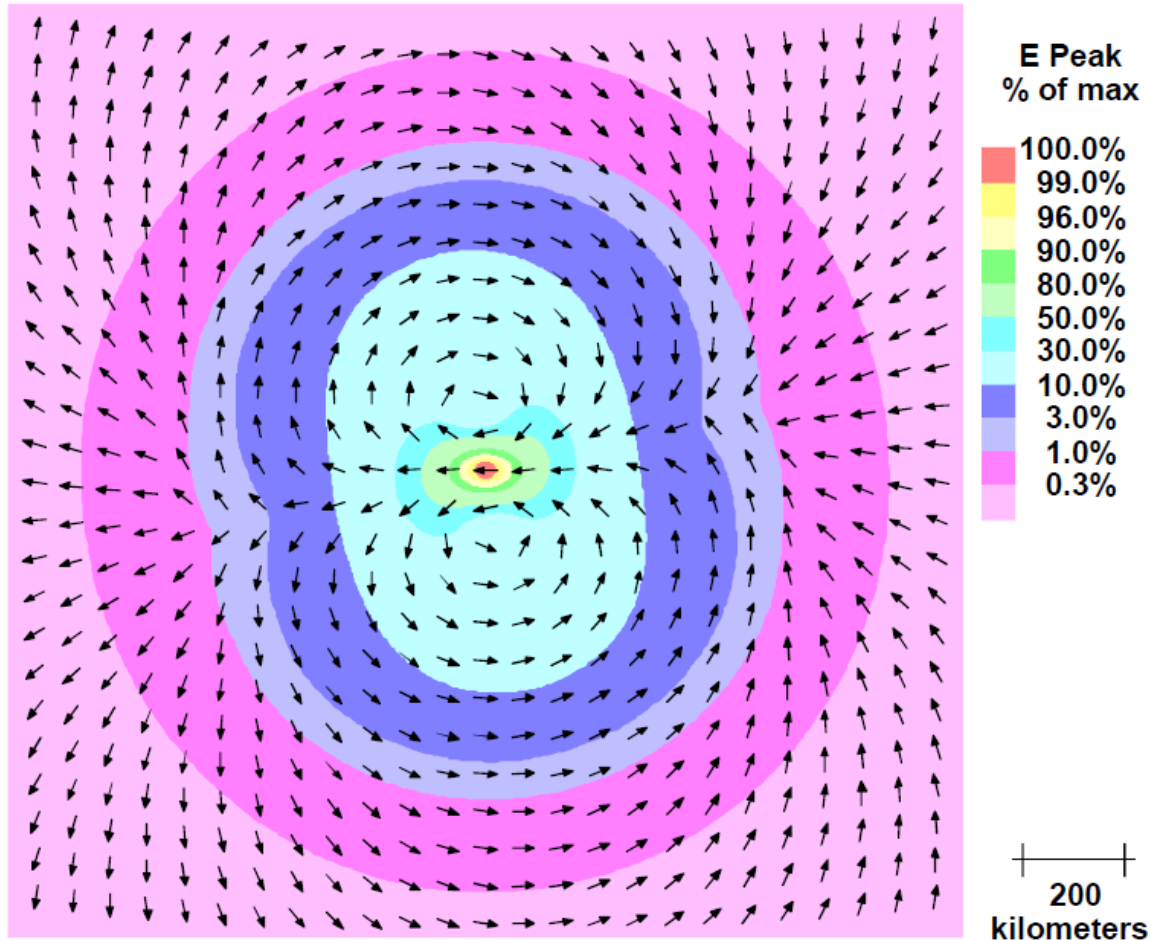

Figure 8
Illustration of static spatial E-field generated by E3B HEMP [17]

GIC Calculations

E3 is a time-varying, non-uniform geomagnetic field at the surface of the earth (refer to Figure 1) that induces time-varying voltages in transmission lines. These induced voltages drive the flow of GIC in transmission lines and grounded wye transformer windings as illustrated in Figure 9.

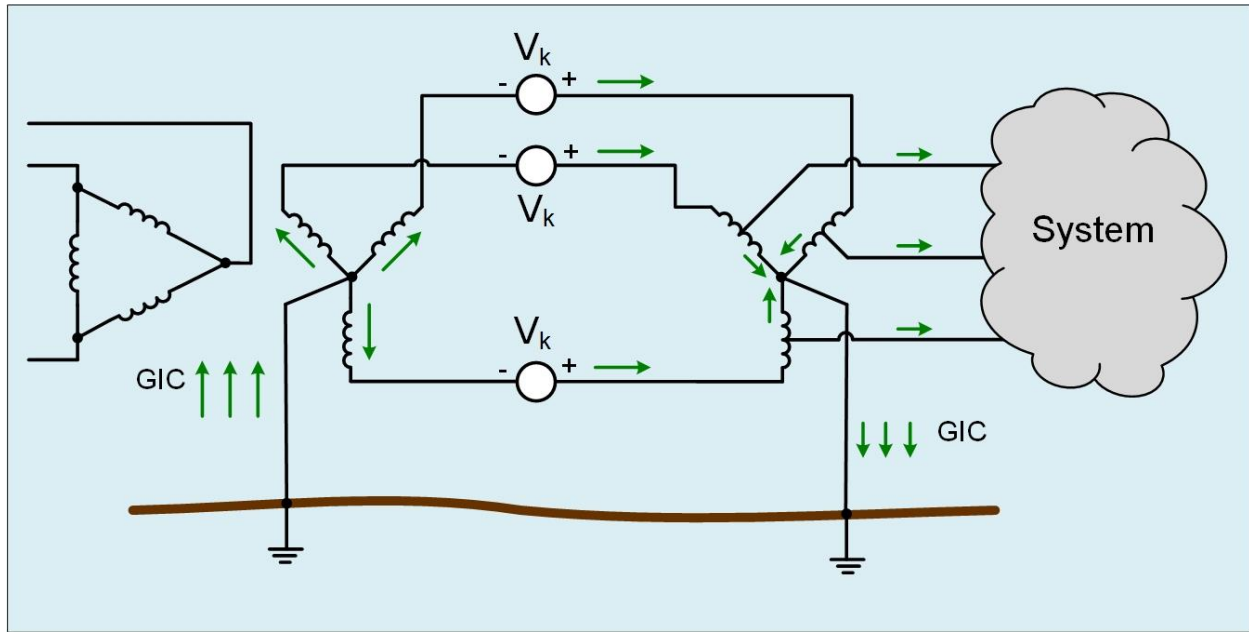

Figure 9
Illustration of GIC flow in a simple power systems

For a given transmission line, the induced voltage, V_k , is determined by integrating the local E-field vector along the transmission line path as shown in Eq. 1.

$$V_k = \oint \vec{E} \cdot d\vec{l} \quad \text{Eq. 1}$$

where:

\vec{E} is the electric field along this route (magnitude and direction), and $d\vec{l}$ is the incremental line segment (magnitude and direction).

The calculation above is performed at each time step of the E-field waveform in order to generate the time-domain voltage waveform that drives the flow of GIC in the network.

When the E-field is highly non-uniform as with E3, lines may need to be broken up into several segments, and the induced voltages are computed using the local E-field associated with each line segment. The induced voltages are then used in combination with the dc model of the power grid to compute the GIC flows. Methods such as the one described in [18] can be used to assemble the model and perform the calculations.

Transformer Thermal Analysis

The flow GIC in transformer windings causes part-cycle saturation. The resulting stray magnetic flux that emanates from the transformer core can induce eddy current heating in transformer windings and structural parts. The consequence of this localized heating can range from accelerated aging of the cellulosic insulation due to thermal degradation to the generation of gas bubbles in the transformer oil [19]. The later can result in imminent failure of the transformer if the bubble migrates to a location within the transformer where there is

a high electric field. Thus, it is important to assess the potential risk that the GIC flows from E3 pose to large power transformers.

Because of the short duration of E3, it is important to employ a time-domain modeling technique to estimate transformer hotspot temperatures. There are various techniques that exist for performing these calculations. For example, the work by EPRI [3] and Marti et al [19] can be used to compute the local hotspot temperatures of transformer windings and structural parts if the GIC flows and transformer design parameters are known.

Stability Analysis

In addition to hotspot heating, transformers that experience part-cycle saturation also absorb large amounts of reactive power and inject harmonic currents into the grid which generate harmonic voltages. The absorption of reactive power makes the transformers appear as large reactive loads on the system. If severe enough, the system cannot support the local reactive power requirements resulting in voltage degradation and potential collapse. The injection of harmonic currents can lead to misoperation of protection systems and potentially cause damage to generators. Harmonic currents can also create voltage distortion that can be transferred to the medium and low voltage systems and potentially impact sensitive loads. Thus, it is important to understand the potential impacts of E3 on the power grid.

As with the transformer thermal assessment, using an approach that captures the appropriate dynamics of the system is of paramount importance. Because of the short duration and extreme nature of E3, time-domain modeling approaches such as those used to perform transient stability analyses have been found to be superior to the steady-state power flow techniques that are often used in geomagnetic disturbance (GMD) assessments [3],[20].

Similar to simulations performed to determine the potential impacts of fault-induced delayed voltage recovery (FIDVR), the dynamic behavior of connected loads is an important aspect of the power system model used to perform E3 assessments. Studies such as those presented in [3] and [20] have demonstrated that the addition of the composite load model¹ and the assumptions made in that load model have a considerable impact on the results of the assessment. It was found that using constant impedance-constant current-constant power (ZIP) models to represent loads yields overly optimistic results. As with all voltage stability related studies, the load level that is evaluated (peak or shoulder case) can also affect the results.

Lastly, the inclusion of under/overvoltage and frequency ride-through capability for generators and overexcitation limiters can also have considerable impact on the results of the assessment. Excluding these features from the models used in the studies of [3] and [20] tended to yield results suggestive of a significantly lower impact.

¹ The composite load model is a time-domain load model that is comprised of a step-down transformer, distribution feeder, shunt compensation and different dynamic load models to more accurately represent the dynamic response of loads to changes in voltage and frequency.

Performance Requirements

Currently, there are no established performance requirements for E3 impacts on the electric grid; however, the steady-state planning requirements for geomagnetic disturbance (GMD) events provided in NERC TPL-007-4 [21] could be used as a potential reference for such requirements. The performance requirements provided in TPL-007-4 are shown in Figure 10 for reference.

Table 1: Steady State Planning GMD Event				
Steady State:				
a. Voltage collapse, Cascading and uncontrolled islanding shall not occur. b. Generation loss is acceptable as a consequence of the steady state planning GMD events. c. Planned System adjustments such as Transmission configuration changes and re-dispatch of generation are allowed if such adjustments are executable within the time duration applicable to the Facility Ratings.				
Category	Initial Condition	Event	Interruption of Firm Transmission Service Allowed	Load Loss Allowed
Benchmark GMD Event – GMD Event with Outages	1. System as may be postured in response to space weather information ¹ , and then 2. GMD event ²	Reactive Power compensation devices and other Transmission Facilities removed as a result of Protection System operation or Misoperation due to harmonics during the GMD event	Yes ³	Yes ³
Supplemental GMD Event – GMD Event with Outages	1. System as may be postured in response to space weather information ¹ , and then 2. GMD event ²	Reactive Power compensation devices and other Transmission Facilities removed as a result of Protection System operation or Misoperation due to harmonics during the GMD event	Yes	Yes
Table 1: Steady State Performance Footnotes				
1. The System condition for GMD planning may include adjustments to posture the System that are executable in response to space weather information. 2. The GMD conditions for the benchmark and supplemental planning events are described in Attachment 1. 3. Load loss as a result of manual or automatic Load shedding (e.g., UVLS) and/or curtailment of Firm Transmission Service may be used to meet BES performance requirements during studied GMD conditions. The likelihood and magnitude of Load loss or curtailment of Firm Transmission Service should be minimized.				

Figure 10
Performance requirements of NERC TPL-007-4

The performance requirements described in Figure 10 are for steady-state analysis whereas the analysis performed to assess the impacts of E3 should be performed in the time-domain using a transient stability or similar software tool. However, these requirements can be used as a notional basis for E3 assessments. The cost to implement NERC TPL-007-4 requirements for an E3 event is likely significantly higher than for GMD events. Thus, these requirements may not be warranted due to the extremely low probability of occurrence of an E3 disturbance, and the cited standard should only be considered a reference as its purpose is not to assess E3 impacts.

Lastly, the effects of E1 and E2, for example damage or disruption of protection and control equipment, should be used to initialize the E3 scenario. Such effects can exacerbate the potential impacts of E3 and are an important consideration [3].

Section 4: Safeguarding Assessments

Data Classification

Utilities generally classify data and results from power grid assessments as proprietary or business confidential information. When data are sensitive or describe a particular vulnerability, utilities can also classify the data as Critical Energy Infrastructure Information (CEII)². However, utilities do not have options of classifying further.

When a nonfederal entity, such as an electric utility, collaborates with a government agency, data should be treated as Controlled Unclassified Information (CUI) and CEII (CUI//CEII). CEII falls within the category of Controlled Unclassified Information (CUI) as defined by the National Institute of Standards and Technology (NIST) [22]. NIST provides guidelines on protecting, handling, and transmitting data for federal and non-federal entities. Therefore, when a nonfederal entity is collaborating with a federal entity both must be compliant with NIST standards to protect and share data.

Data Storage and Handling

Nonfederal entities have their own processes to protect internal sensitive data as well as cyber assets and do so by complying with various industry standards and best practices. In general, digital information is kept on an internal network like a server behind a firewall and access is limited to authorized users.

NIST standard SP-800-171 [22] provides guidelines for nonfederal entities to store and handle CUI when such a need is identified, for example sharing CEII with a government agency. The main steps to implementing the NIST standard are: locating and identifying CUI, separating CUI from non-CUI data, applying required controls, monitoring all CUI data, train personnel, and maintain the integrity of the system through assessments and process updates.

Sharing Data with U.S. Government Agencies

When sharing data between a nonfederal entity and U.S. government agencies (USGA), both should comply with all relevant NIST standards. Some methods that have been used to transmit CEII or CUI data securely are secure file transfer protocol (SFTP), end-to-end encrypted links or services, password protected documents sent through enterprise email service with the password to the document sent in separate email, secure login to host location of data on internal server, and third-party file transfer software such as Dropbox or OneDrive. Any data being transmitted from a nonfederal entity to a USGA should be done

² Critical Electric Infrastructure Information (CEII) refers to critical electric infrastructure information that is designated as critical electric infrastructure by the Federal Energy Regulatory Commission (FERC) or the Secretary of the Department of Energy pursuant to section 215A(d) of the Federal Power Act. CEII is exempt from mandatory disclosure under the Freedom of Information Act, 5 U.S.C. 552(b)(3) and shall not be made available by any Federal, State, political subdivision or tribal authority pursuant to any Federal, State, political subdivision or tribal law requiring public disclosure of information or records pursuant to section 215A(d)(1)(A) and (B) of the Federal Power Act. See 18 C.F.R. § 388.113.

through an agreement mechanism such as a contract and should consider including terms on how the data can be used and disseminated outside of the specific USGA.

Any data or assessment report that will be available to the public sector from the nonfederal entity or USGA should be reasonably sanitized of trade information, material that can identify vulnerabilities, and/or negatively impacts national security.

An example of the process that the Federal Energy Regulatory Commission (FERC) uses to store and protect CEII it receives can be found at <https://cms.ferc.gov/cui> [23].

Section 5: References

1. United States Department of Energy, "DOE Memorandum: Physical Characteristics of HEMP Waveform Benchmarks for Use in Assessing Susceptibilities of the power Grid, Electrical Infrastructures, and other Critical Infrastructure to HEMP Insults," January 2021.
2. Los Alamos National Laboratory, "EMP/GMD Phase 0 Report, A Review of EMP Hazard Environments and Impacts," Los Alamos, NM, 2016.
3. High-Altitude Electromagnetic Pulse and the Bulk Power System: Potential Impacts and Mitigation Strategies, EPRI, Palo Alto, CA, 2019. 3002014979.
4. Oak Ridge National Laboratory, "Electromagnetic Pulse Research on Electric Power Systems: Program Summary and Recommendations," 1993.
5. International Electrotechnical Commission, "IEC 61000-5-9: Electromagnetic compatibility (EMC) - Part 5-9: Installation and mitigation guidelines - System-level susceptibility assessments for HEMP and HPEM.
6. Department of Defense, "MIL-STD-188-125-1: High-Altitude Electromagnetic Pulse (HEMP) Protection for Ground-based C4I Facilities Performing Critical, Time-urgent Missions," DOD, 1998.
7. F.M. Tesche, P.R. Barnes, "A Multiconductor Model for Determining the Response of Power Transmission and Distribution Lines to a High-Altitude Electromagnetic Pulse (HEMP)", IEEE Transactions on Power Delivery, Vol. 4, No. 3, July 1989.
8. C. D. Taylor, R. S. Sattewhite and C. W. Harrison, Jr., "The Response of a Terminated Two-Wire Transmission Line Excited by a Nonuniform Electromagnetic Field," IEEE Trans. Ant. Prop., vol. e, pp. 987-989, 1965.
9. K. Agrawal, "Transient Response of Multiconductor Transmission Lines Excited by a Nonuniform Electromagnetic Field," IEEE Transactions on Electromagnetic Compatibility, 1980.
10. R. Olsen, "EMP Coupling to a Straight Conductor Above Ground: Transmission Line Formulation Based on Electromagnetic Reciprocity", IEEE Transactions on Electromagnetic Compatibility, June 2018.
11. E. Vance, Electromagnetic-Pulse Handbook for Electric Power Systems, Stanford Research Institute, June 1974.
12. F. M. Tesche, EMC Analysis Methods and Computational Models, New York: Wiley, 1997.
13. H. Xie, "Theoretical and experimental study of effective coupling length for transmission lines illuminated by HEMP," IEEE Transactions on Electromagnetic Compatibility, Vol. 57, no. 6, pp. 1529-1538, Aug. 2015.
14. Donald White, Shielding Design: Methodology and Procedures, Interference Control Technologies, Inc., 1986.
15. Shielding Design of Substation Control Buildings to Mitigate the Effects of E1 HEMP. EPRI, Palo Alto, CA: 2020. 3002019586.
16. IEEE Std. 1313.2-R2005, IEEE Guide for the Application of Insulation Coordination
17. The Commission to Assess the Threat to the United States from Electromagnetic Pulse (EMP) Attack, Recommended E3 HEMP Heave Electric Field Waveform for the Critical Infrastructures, July 2017.

18. North American Electric Reliability Corporation (NERC), "Application Guide: Computing Geomagnetically-Induced Current in the Bulk-Power System," North American Electric Reliability Corporation (NERC), 2013. https://www.nerc.com/comm/PC/Geomagnetic%20Disturbance%20Task%20Force%20GMDTF%202013/GIC%20Application%20Guide%202013_approved.pdf
19. L. Marti, A. Rezaei-Zare, and A. Narang, "Simulation of Transformer Hotspot Heating Due to Geomagnetically Induced Currents," IEEE Transactions on Power Delivery, vol. 28, no. 1, pp. 320–327, 2013.
20. Magnetohydrodynamic Electromagnetic Pulse Assessment of the Continental U.S. Electric Grid: Voltage Stability Analysis. EPRI, Palo Alto, CA: 2017. 3002011969.
21. North American Electric Reliability Corporation (NERC), "Transmission System Planned Performance for Geomagnetic Disturbance Events, TPL-007-4." <https://www.nerc.com/pa/Stand/Reliability%20Standards/TPL-007-4.pdf>
22. R. Ross, V. Pillitteri, K. Dempsey, M. Riddle and G. Guissanie, "SP 800-171 Rev. 2: Protecting Controlled Unclassified Information in Nonfederal Systems and Organizations," National Institute of Standards and Technology, 2020.
23. CUI Processes: <https://cms.ferc.gov/cui>.

About EPRI

Founded in 1972, EPRI is the world's preeminent independent, non-profit energy research and development organization, with offices around the world. EPRI's trusted experts collaborate with more than 450 companies in 45 countries, driving innovation to ensure the public has clean, safe, reliable, affordable, and equitable access to electricity across the globe. Together, we are shaping the future of energy.



CESER

TECHNICAL ANALYSIS REPORTS